

F60180

Instruction Manual

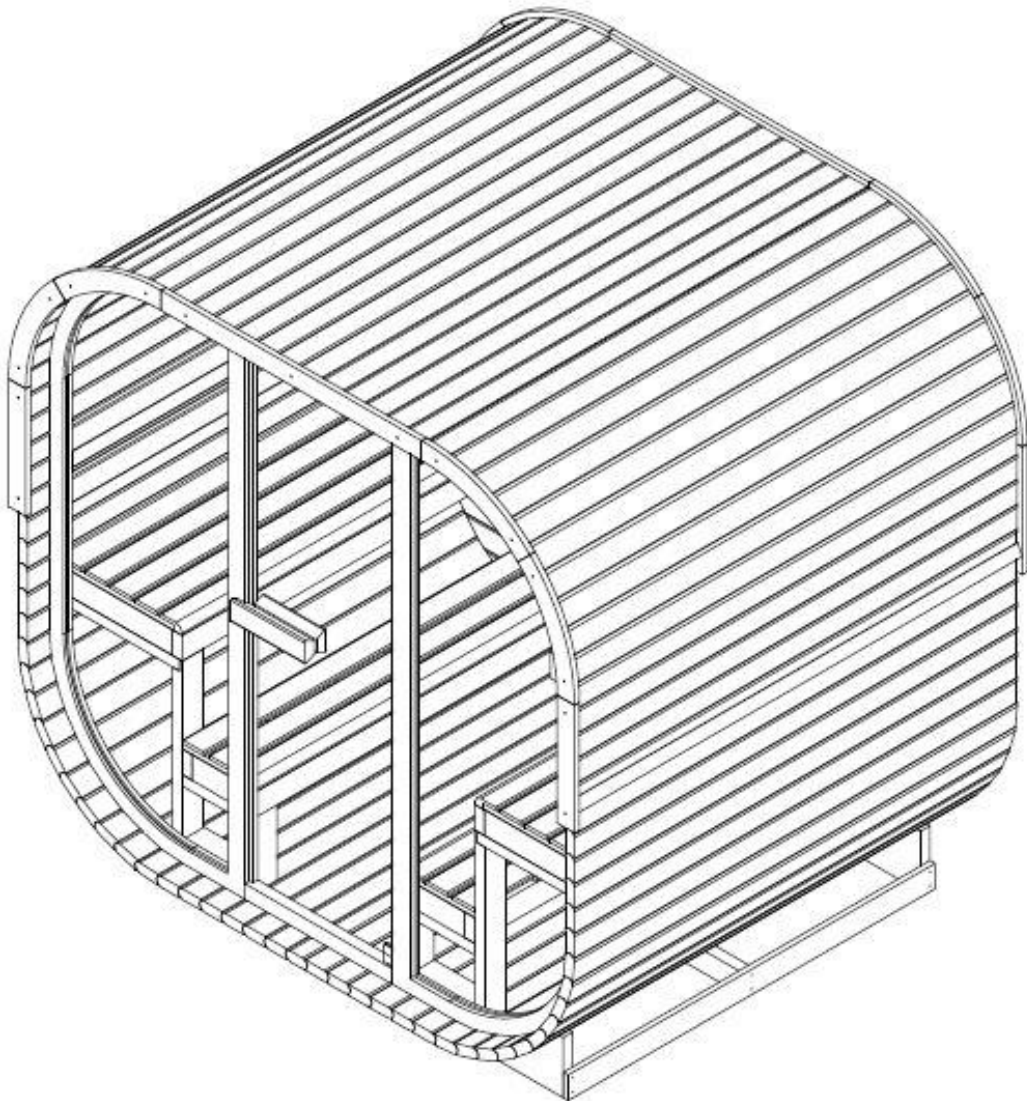

Attention

Read these instructions carefully before using your sauna for the first time.

We recommend that you store it in a safe place so that you can use it again in the future.

Please make a note of the serial number of the cabin control box, as this number will be required in the event of a repair or spare parts order.

- Wood is a living element. To maintain its original appearance, it is important to treat the outside of the wood against moisture.
- Place the sauna on a perfectly flat and hard surface.
- Do not use liquid cleaning agents. Switch off the sauna before cleaning and use a damp cloth.
- Protect the sauna's power cable so that it is not crushed or pinched.
- Before replacing certain components, make sure that they are prescribed by the manufacturer or have the same properties as the original parts. Incorrect replacement can cause a fire, short circuit or damage to the sauna. We strongly recommend that you consult a qualified technician.
- To avoid the risk of burns or electric shocks, do not use metal tools.
- Animals must not be brought into the sauna.
- Do not leave the sauna switched on unattended.
- Do not leave the sauna switched on for more than 1 hour at a time to avoid premature damage to the appliance. Switch the sauna off for at least 30 minutes after 1 hour of continuous operation.
- It is recommended not to install a locking system on the sauna door.
- Before connecting the sauna to the power supply, check that your electrical installation meets the requirements.
- Installation and repairs may only be carried out by a qualified electrician!
- Only use original parts.
- Switch off the sauna when not in use.

DANGER

- Covering the ovens leads to a fire hazard due to overheating. Do not cover the heating elements!
- Always keep flammable or highly flammable materials/objects (e.g. towels) away from the heater.
- Do not touch the heater during and shortly after use, as there is a risk of burns from the hot parts.
- The light bulb heats up during operation. If the light bulb needs to be replaced, unplug the heater from the cabin and allow the light bulb to cool down

Safety

IMPORTANT!

Please read the safety instructions carefully before setting up and using your sauna cabin.
The instructions are important for your safety, so please adhere strictly to them.

Achten Sie auf Hyperthermie, Hitzschlag oder Hitzeerschöpfung, die durch Nichtbeachtung der Sicherheitshinweise verursacht oder verschlimmert werden können. Die Symptome sind Fieber, schneller Puls, Schwindel, Ohnmacht, Lethargie und Taubheitsgefühl im ganzen Körper oder in Teilen des Körpers. Die Auswirkungen sind: verminderte Wahrnehmung der Hitze, Unkenntnis der drohenden Gefahren, Bewusstlosigkeit.

Watch out for hyperthermia, heat stroke or heat exhaustion, which can be caused or worsened by not following the safety instructions. Symptoms include fever, rapid pulse, dizziness, fainting, lethargy and numbness throughout the body or in parts of the body. The effects are: reduced perception of heat, lack of awareness of impending danger, unconsciousness.

The sauna may not be used by:

- Children under 6 years of age.
- People with strong reactions to sunlight.
- People with pre-existing conditions such as heart disease, high or low blood pressure, circulatory disorders or diabetes without prior medical advice.
- Pregnant women. Excessive temperature can endanger the fetus.
- People suffering from dehydration, open wounds, eye diseases, burns or sunstroke.

Children between the ages of 6 and 16 may use the sauna provided they are constantly supervised by a responsible adult and the temperature does not exceed 60°C.

If you have health problems, are taking medication or have injured muscles or ligaments, you may only use the sauna after prior consultation with and approval from a doctor.

If you have surgical implants, you may not use the sauna without first consulting a doctor and obtaining their approval.

Do not use the sauna after strenuous activity. Wait 30 minutes until your body has cooled down.

Do not spend more than 40 minutes at a time in the sauna.

Do not consume alcohol or drugs before or during the session.

Do not sleep in the sauna when it is in operation.

To avoid the risk of overheating, connect your sauna to a sufficiently powerful socket and do not connect any other electrical appliances to the same socket.

To avoid the risk of electric shock or damage to the sauna, it must not be used:

- During a thunderstorm.
- If the electrical cable is damaged, it must be replaced by a qualified person.
- If the power cable overheats, it must be checked by a qualified person.
- If you need to change a light bulb, wait until the sauna is switched off and has cooled down.
- Dry your hands before connecting or disconnecting the power.

Never work with wet hands or feet.

Do not switch the power or heating on or off quickly, as this could damage the electrical system.

Do not attempt to repair the sauna yourself without the consent of the sauna dealer or the manufacturer.

Unauthorized repair attempts will void the manufacturer's warranty.

Do not use cleaning agents in the sauna.

Do not stack or store any objects in or on the sauna.

Do not place any flammable materials or chemical substances near the sauna.

Do not cover the heating elements!

Do not touch the heater during and shortly after use, as there is a risk of burns due to the hot parts.













Switch off the cabin when not in use.

Technical data:

Model	F60180
Cabin Material	Spruce wood
Depth	2100mm
Width	1800mm
Height	2100mm
Voltage	AC 230V
Sauna Stove	8 KW

Assembly material (deviations possible)

Please remove the transport packaging and check that your infrared cabin has been delivered complete and undamaged before you start assembling it.

															
Ø4x18	Ø4x30	Ø4x40	Ø4x45	Ø4x60	Ø3*16	Ø6x50	Ø12x200								
64x	4x	220x	28x	50x	4x	2x	2x	4x	2x	4x	4x	1x	2x	2x	16x

Read the assembly instructions carefully before you have found a suitable place for your sauna.

The sauna is designed for outdoor installation only.

Select an area:

- In a dry place on a flat, stable surface that can support the weight of your sauna.
- The height must be sufficient to allow you to reach the ceiling and carry out electrical connections and maintenance work.
- Keep away from water sources, flames or flammable materials.

Practical advice

- Please note that at least 2 adults are required to set up the sauna.
- Identify each panel clearly before you start
- When installing, lay the power cable of your sauna so that it is easily accessible.
- Please note that there are differences between the models.

IMPORTANT :









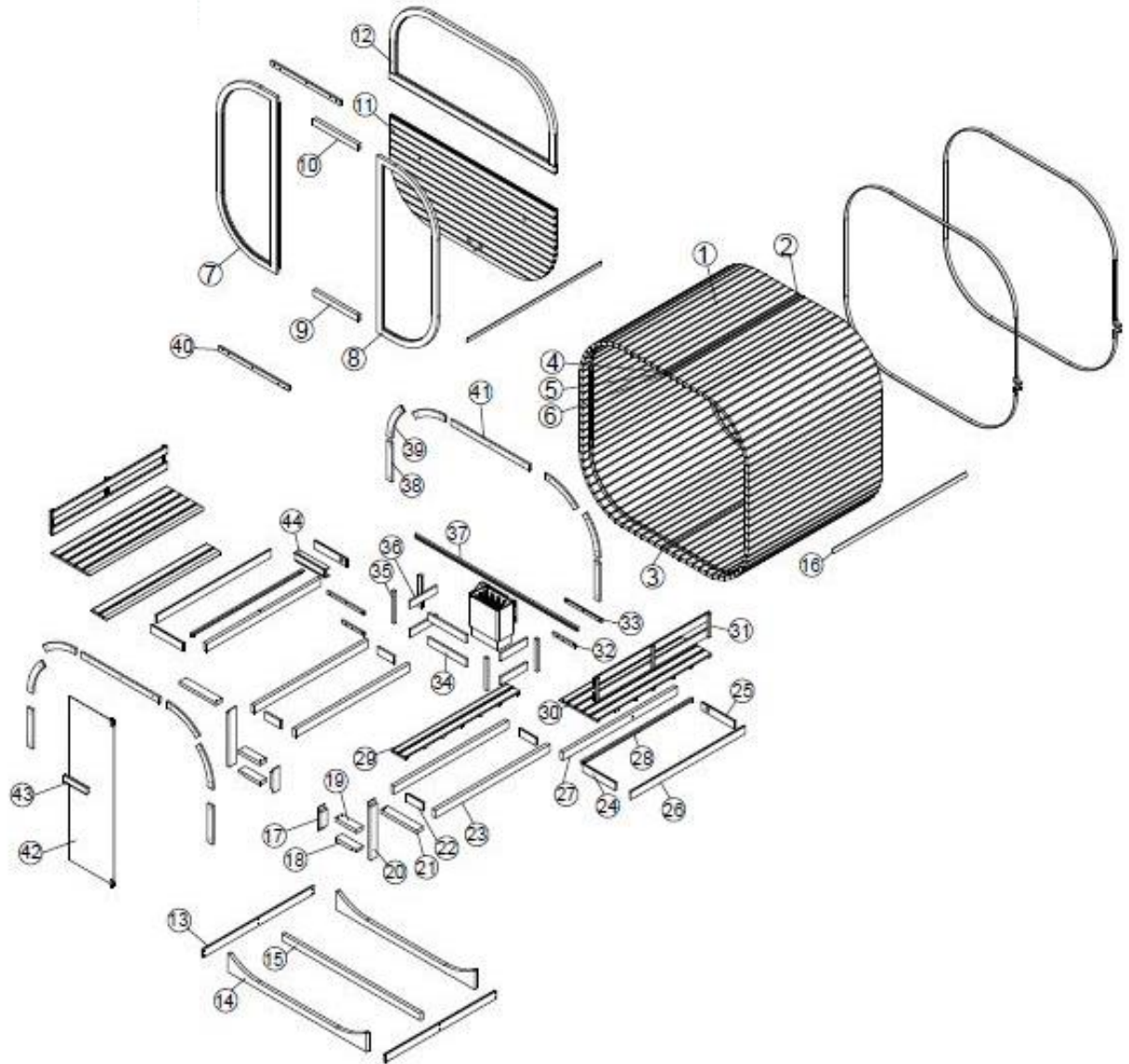



Please check the countersink and hole diameter of the drill holes to avoid damaging the wood.











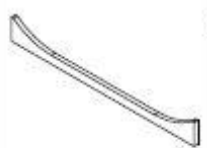

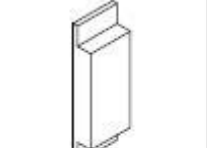
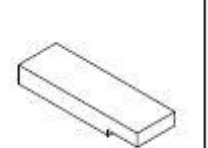
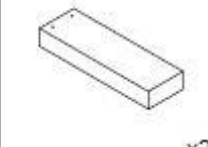
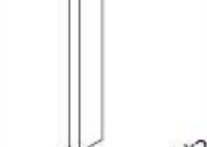
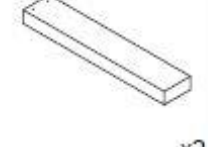
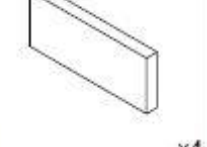

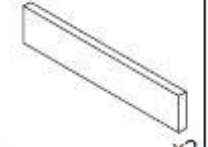





Tool:

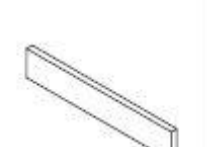
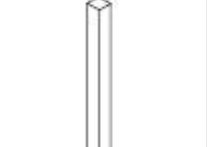
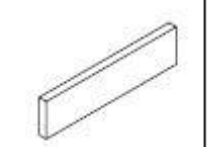

Partslist:

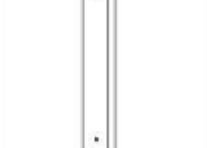

①	②	③	④	⑤	⑥
					
x76	x2	x2	x1	x1	x1
1800*96*38	1800*45*38	1800*45*38	1800*30*38	1800*20*38	1800*10*38
⑦	⑧	⑨	⑩	⑪	⑫
					
x1	x1	x1	x1	x1	x1
1958*710*38	1958*710*38	600*70*38	600*70*38	2018*1034*38	2018*934*38

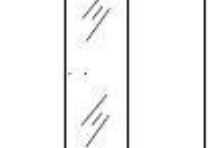
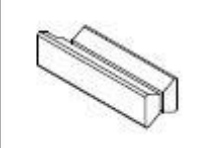
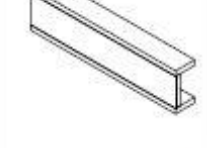
13  x2	14  x2	15  x1	16  x2	17  x2	18  x2
1492*90*20	1661*212*38	1661*79*38	1800*40*20	270*90*40	185*90*40
19  x2	20  x2	21  x2	22  x4	23  x5	24  x2
185*90*40	659*90*40	485*90*40	118*90*20	1535*90*40	438*90*20
25  x2	26  x2	27  x1	28  x2	29  x2	30  x2
438*90*20	1535*90*20	1535*90*40	1490*25*20	1535*200*33	1535*500*33
31  x2	32  x2	33  x2	34  x2	35  x4	36  x2
1535*230*33	300*33*20	495*33*20	515*90*20	330*33*33	340*90*20
37  x1	38  x4	39  x8	40  x2	41  x2	42  x1
1980*40*20	400*70*20	475*70*20	739*40*20	860*70*20	1903*596*8
43  x1	44  x1	45	46	47	48
300*80*40	400*103*53				

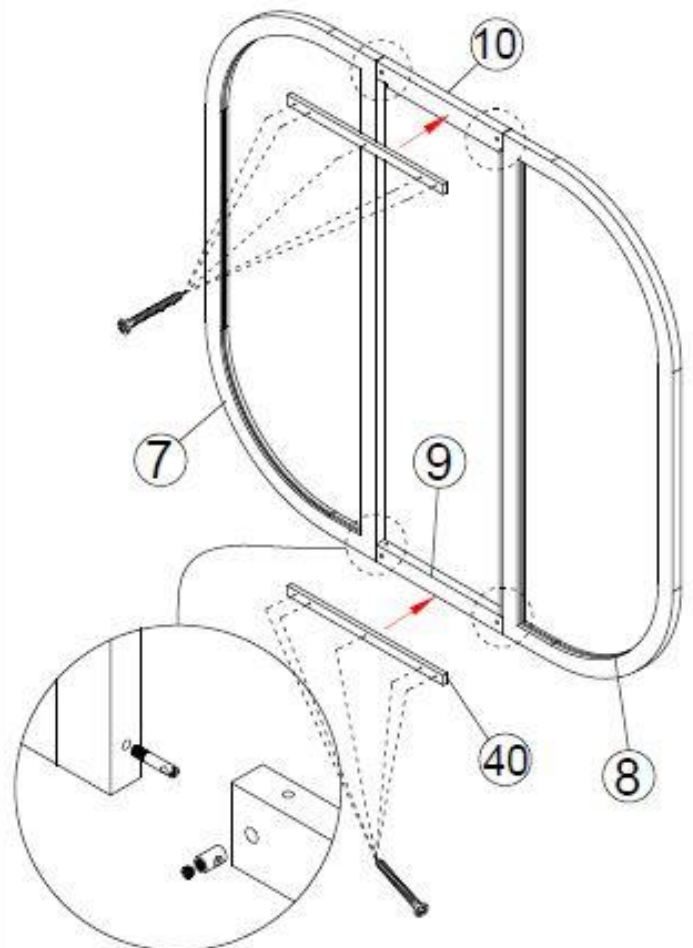
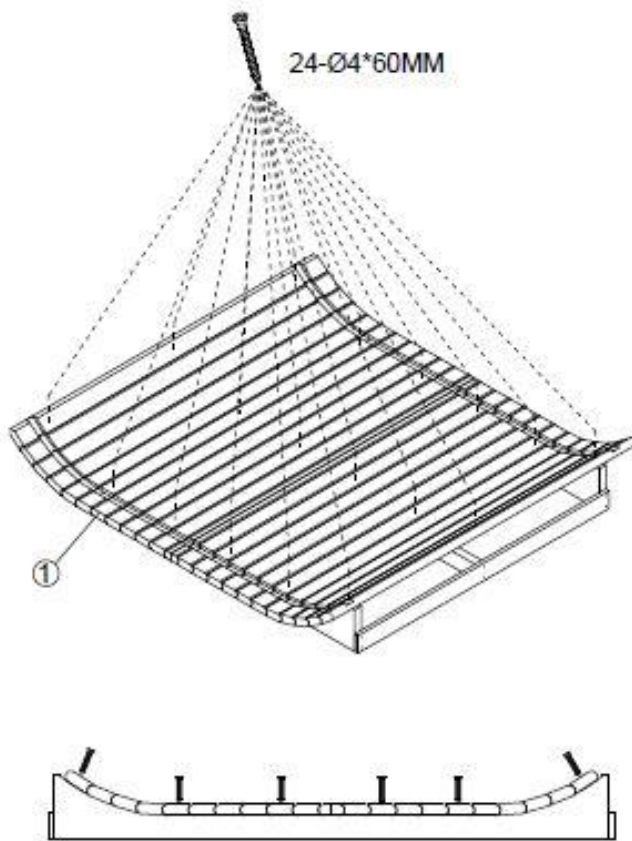
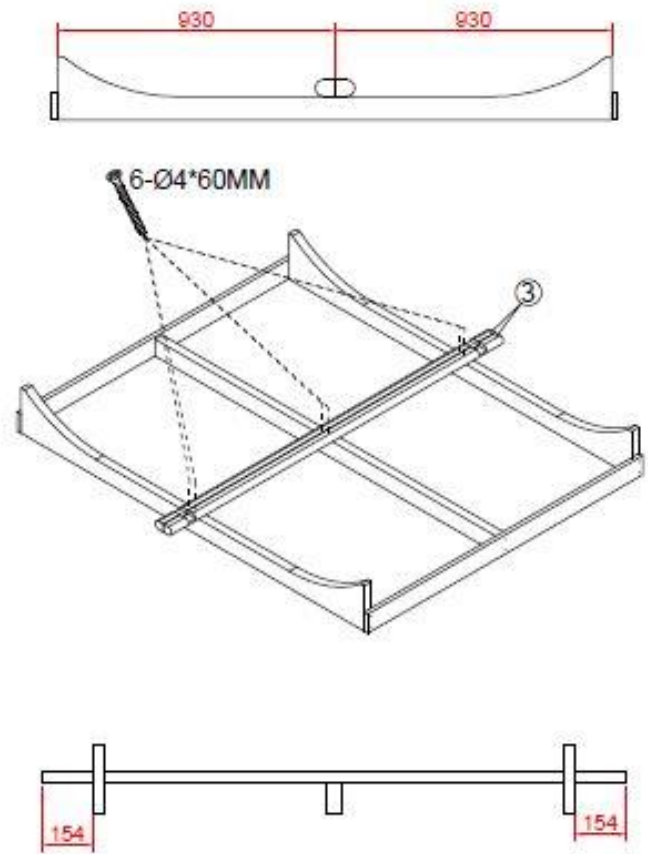
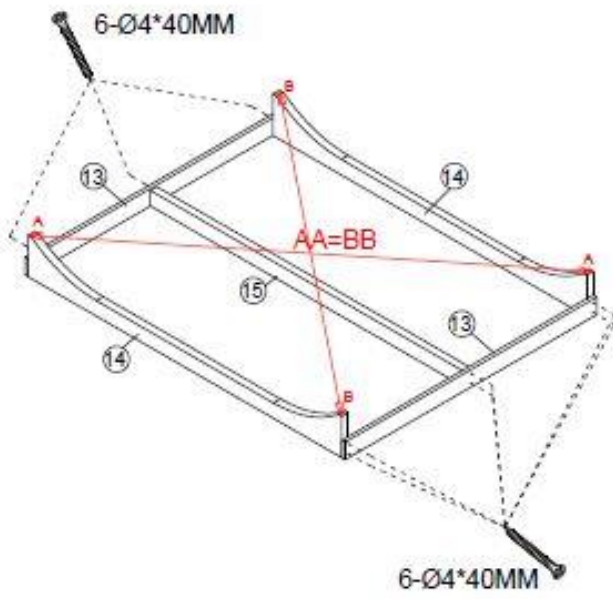

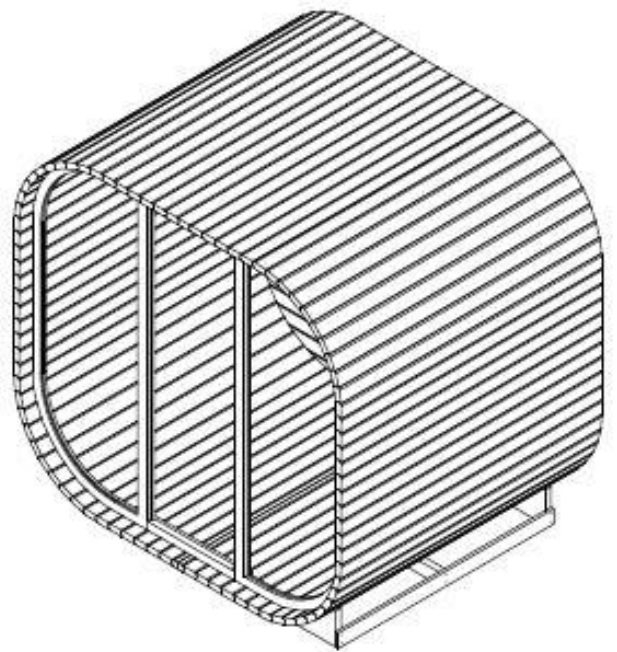
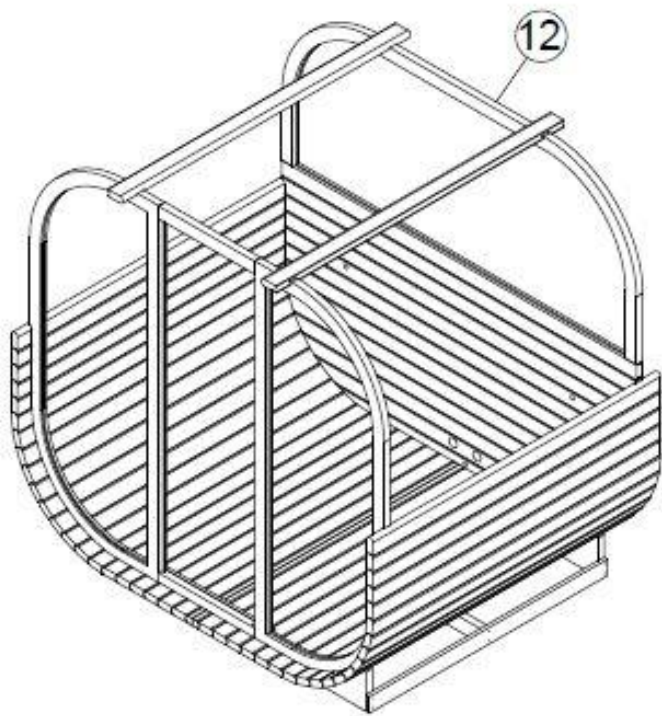
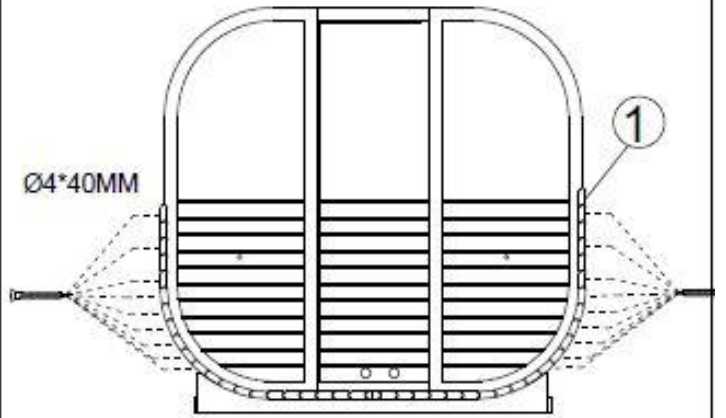
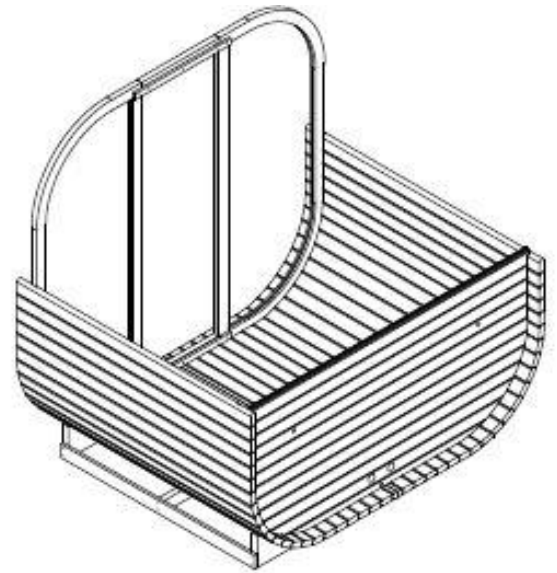
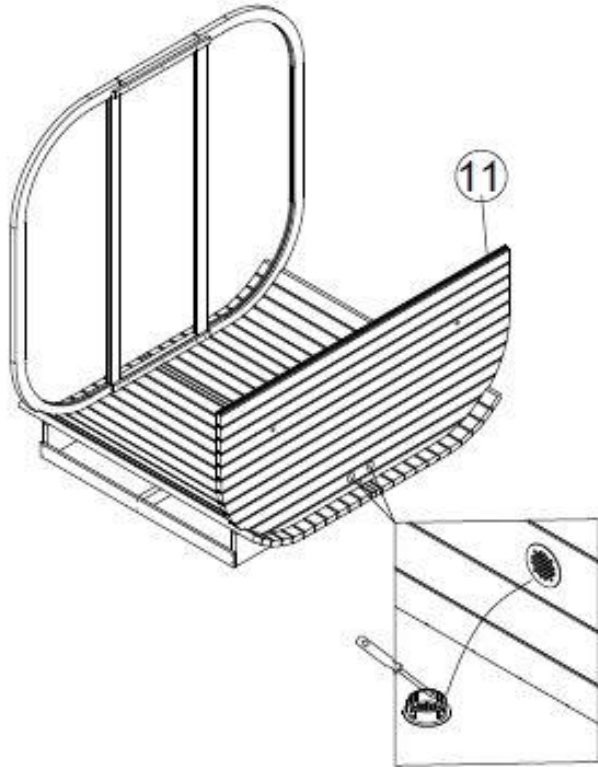

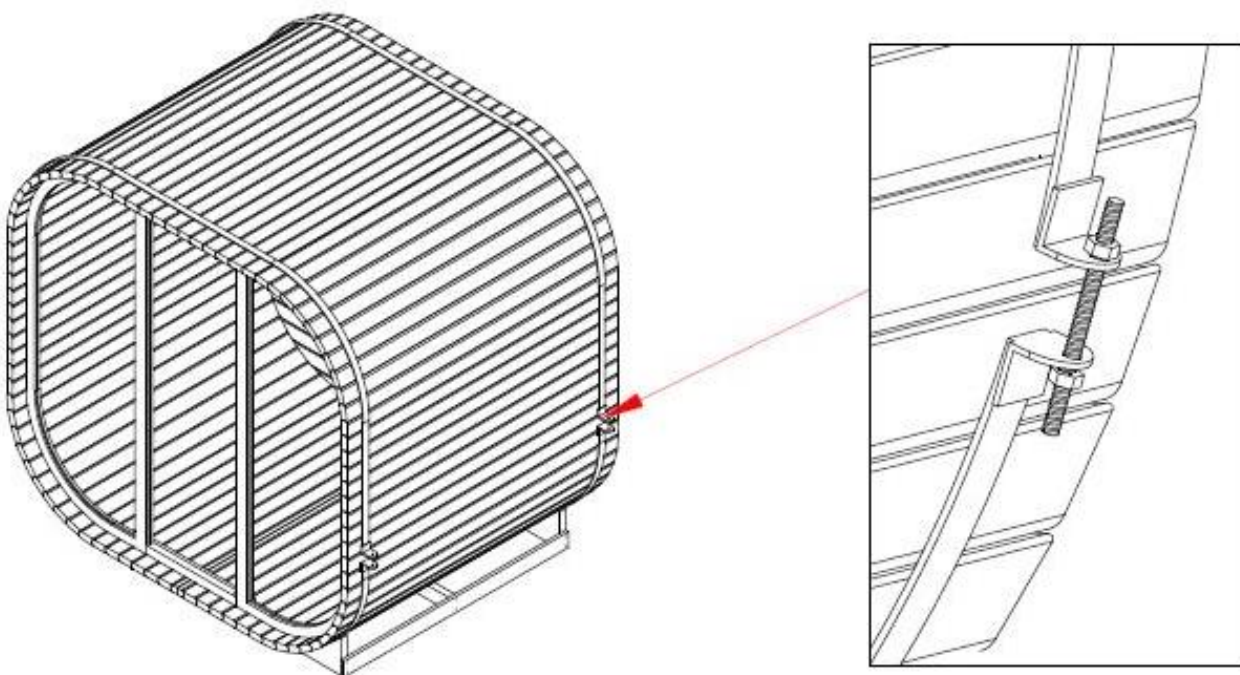
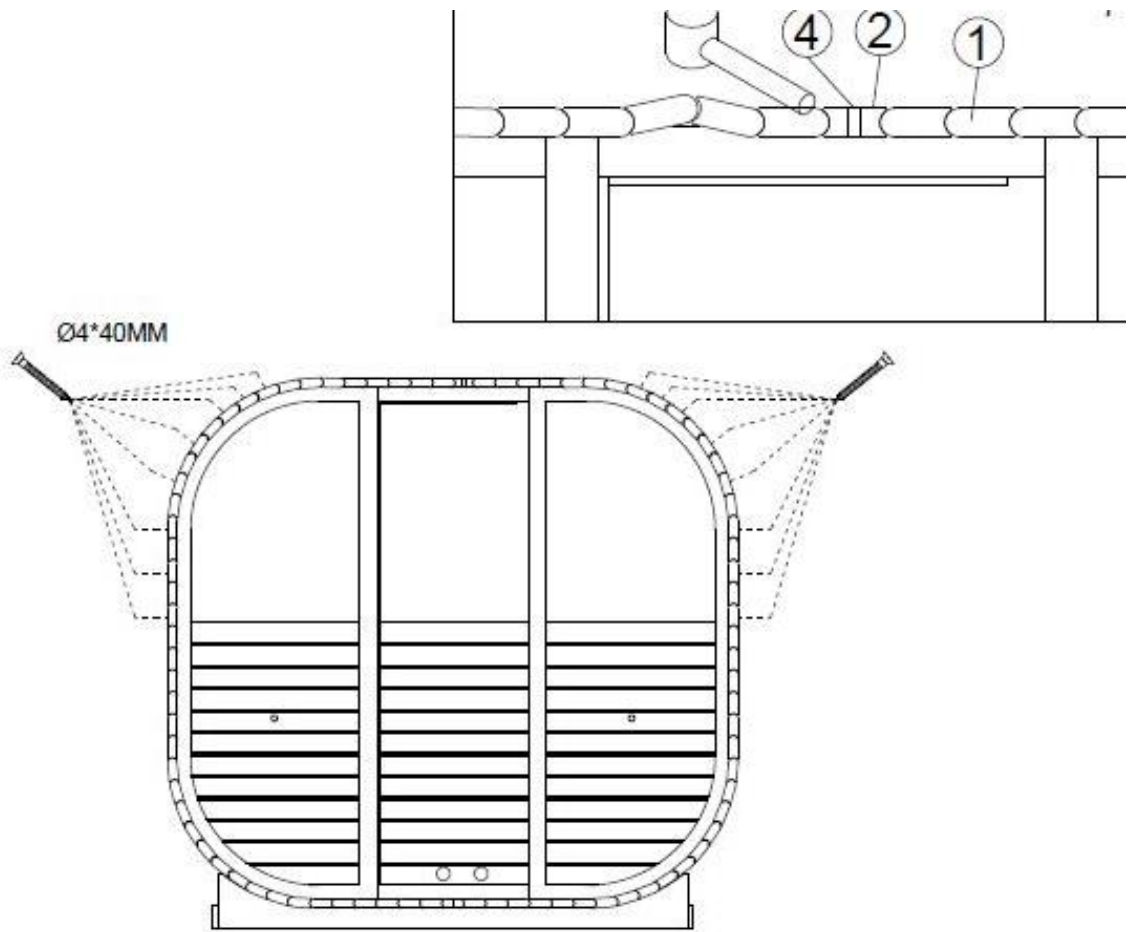

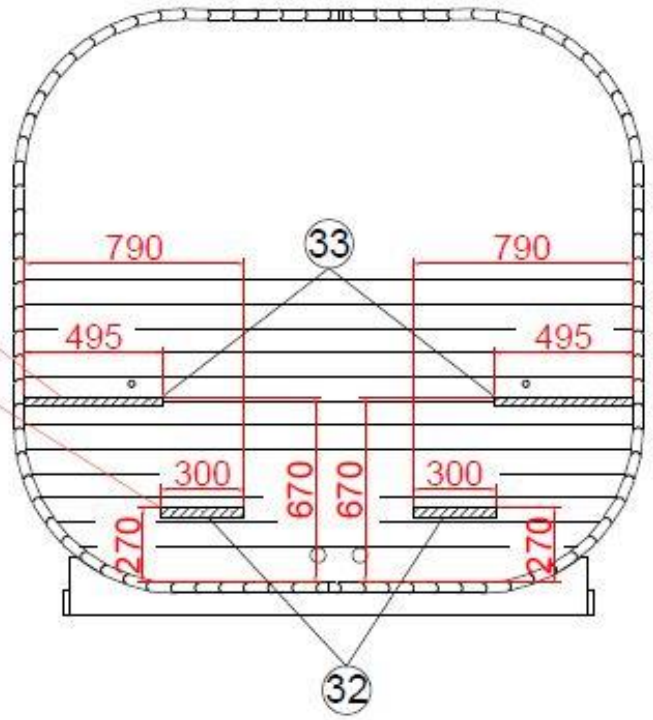
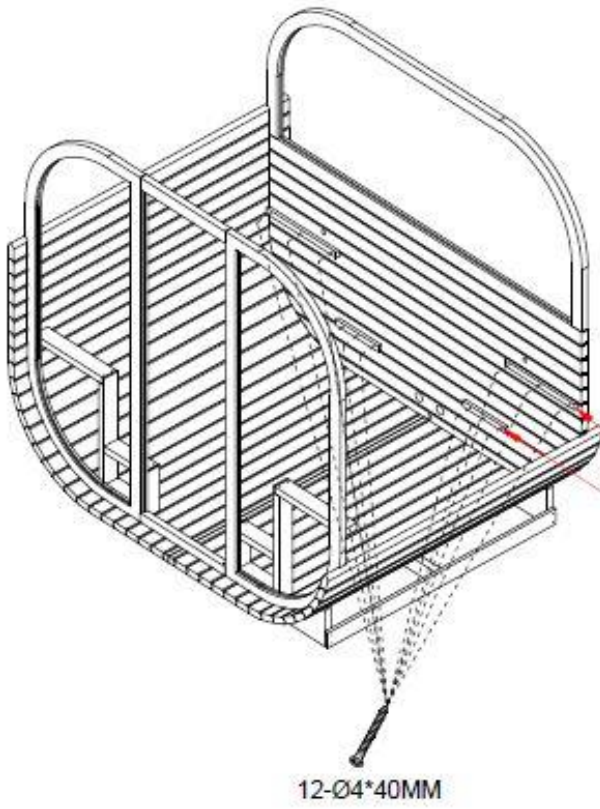
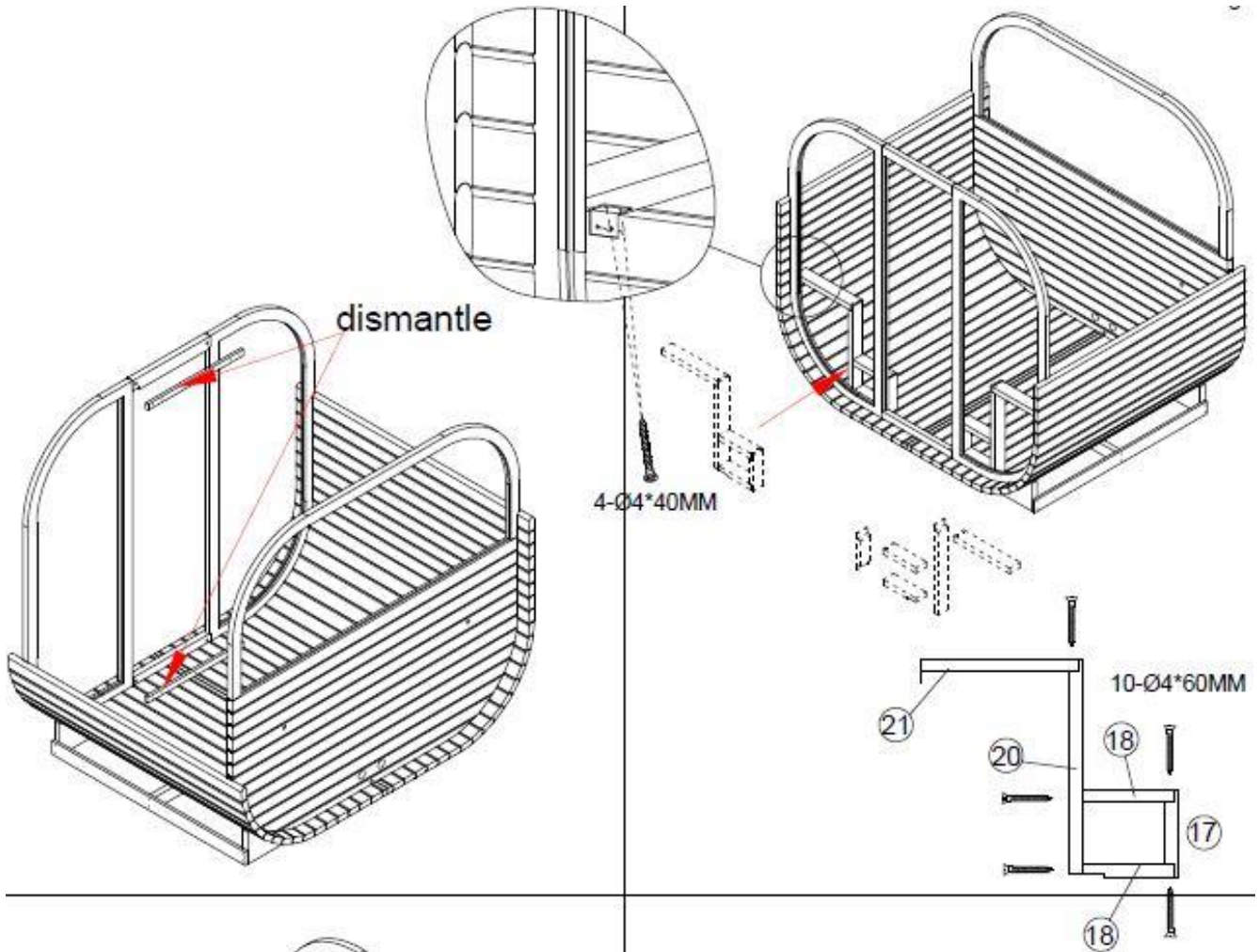

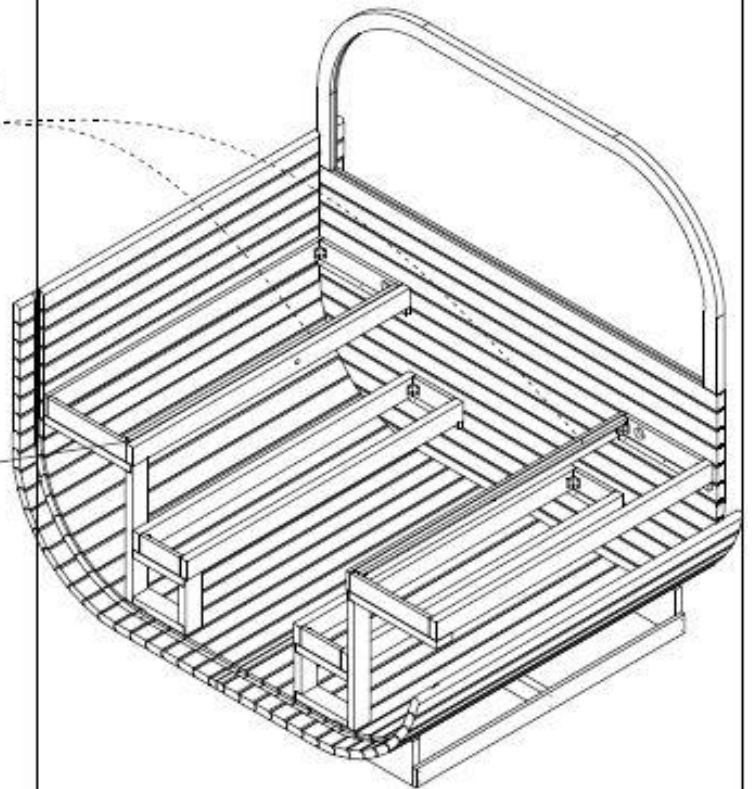
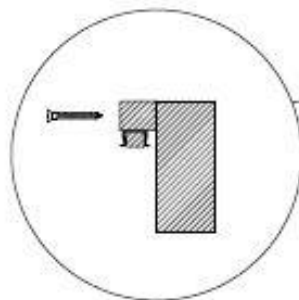
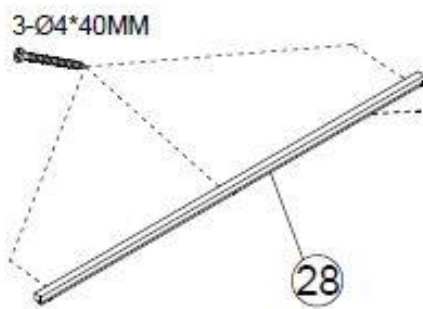
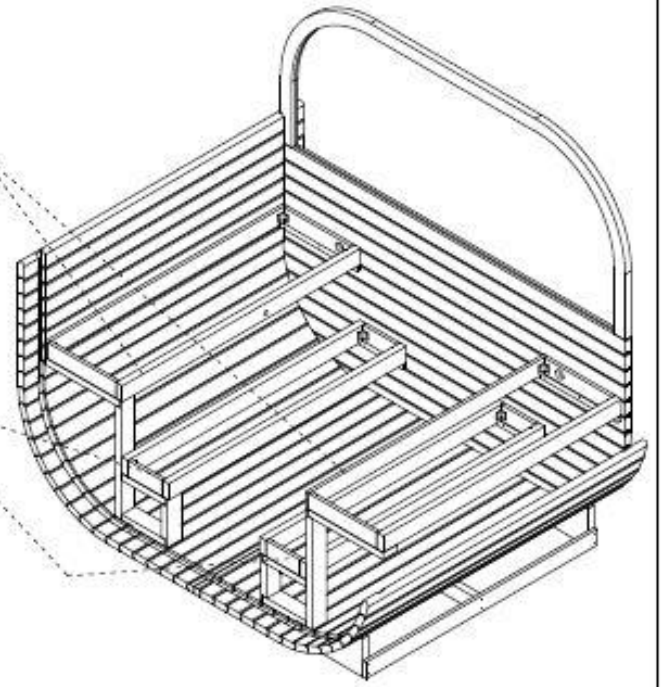
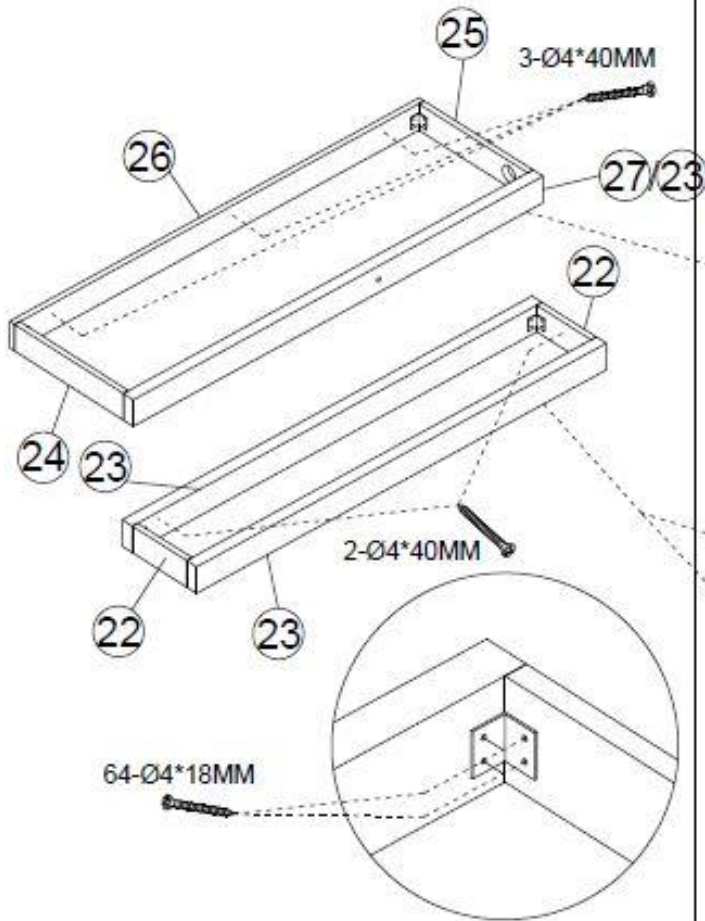

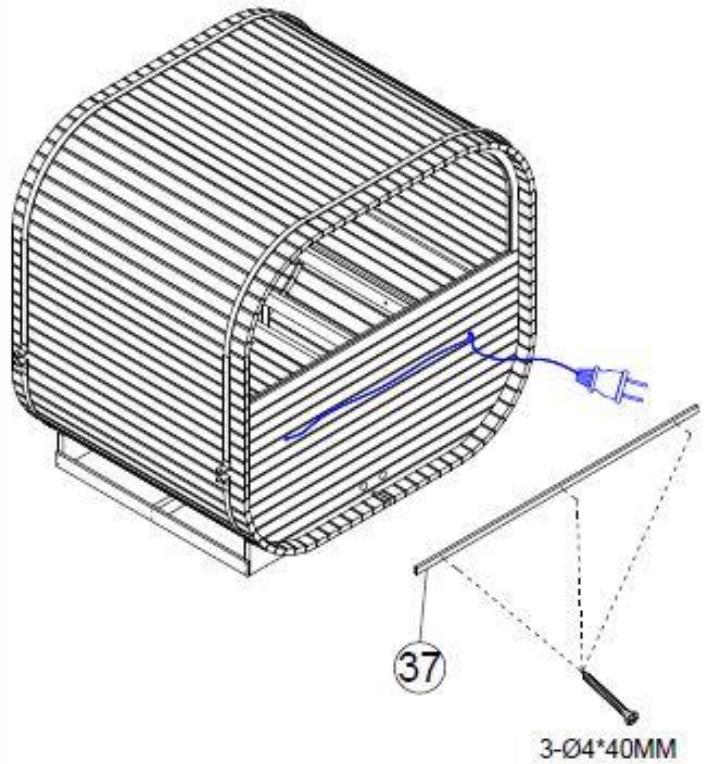
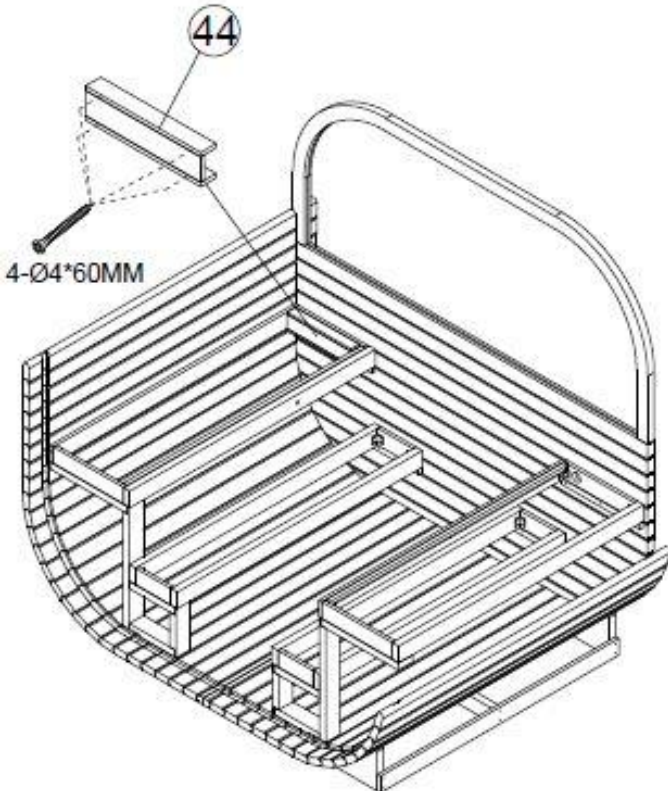
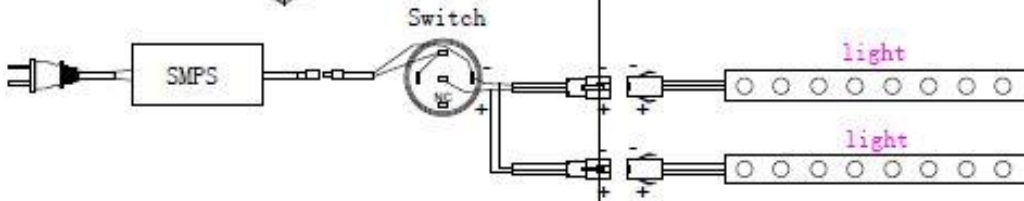
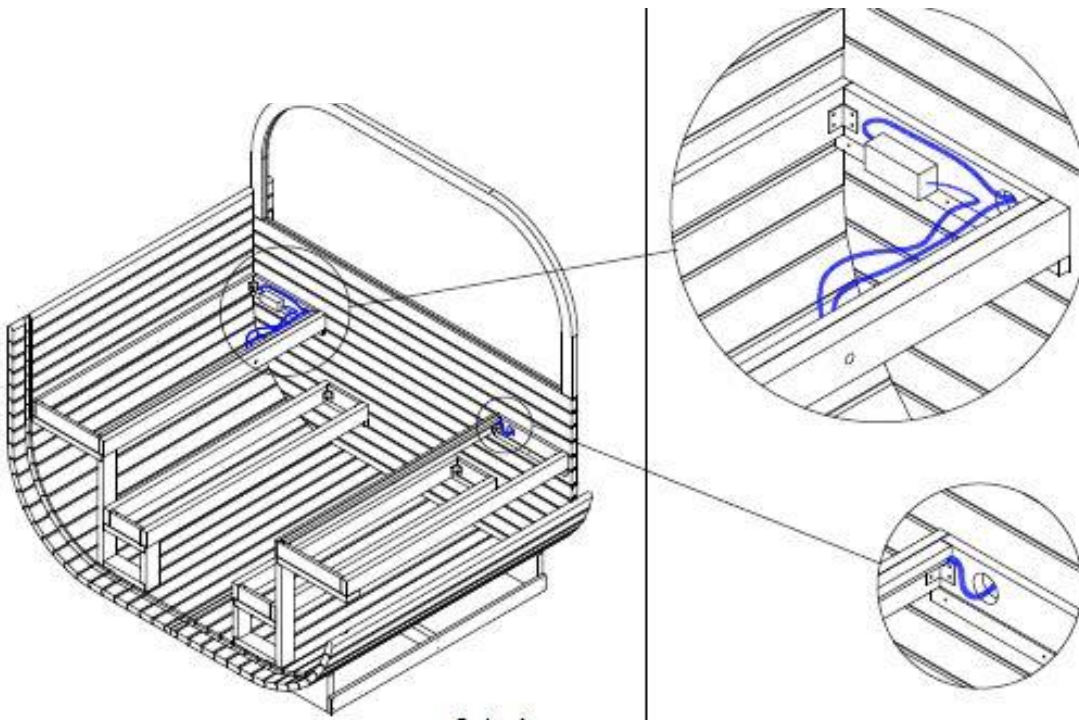

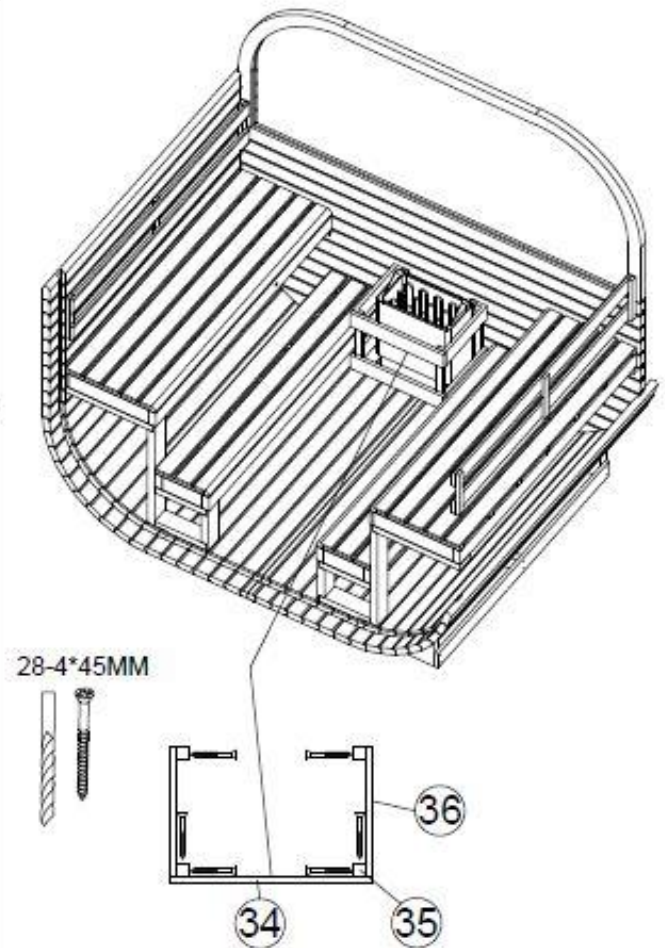
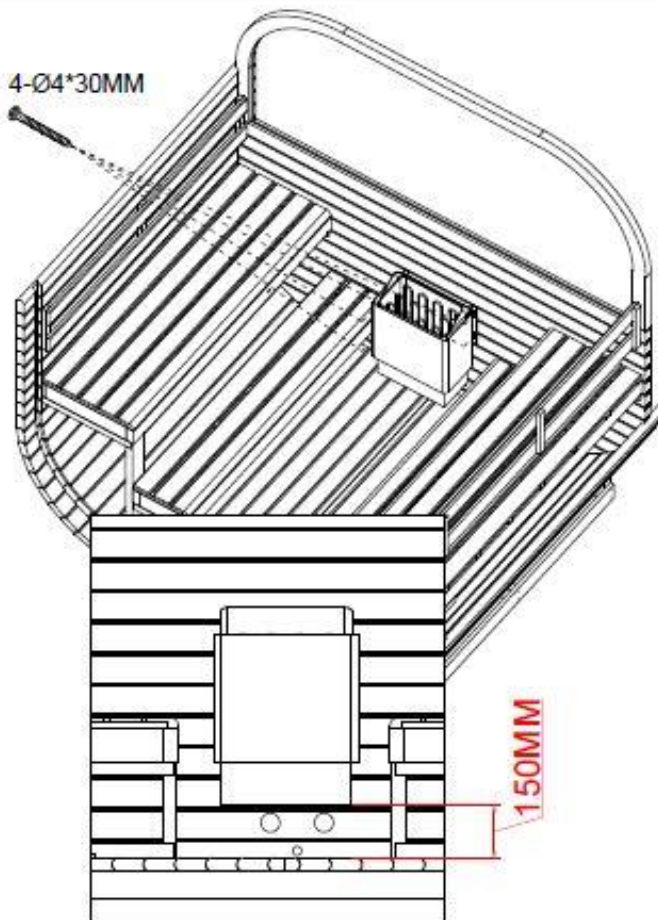
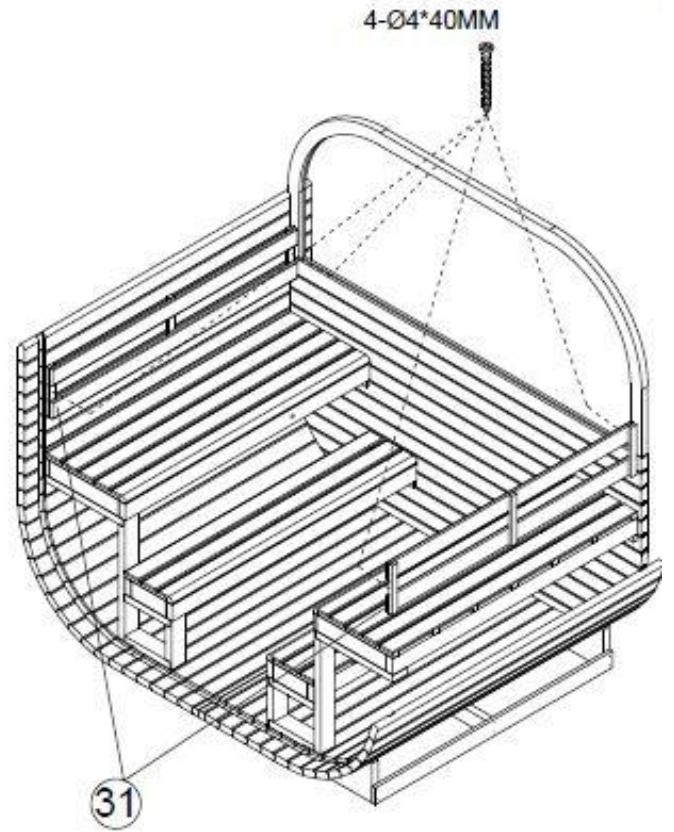
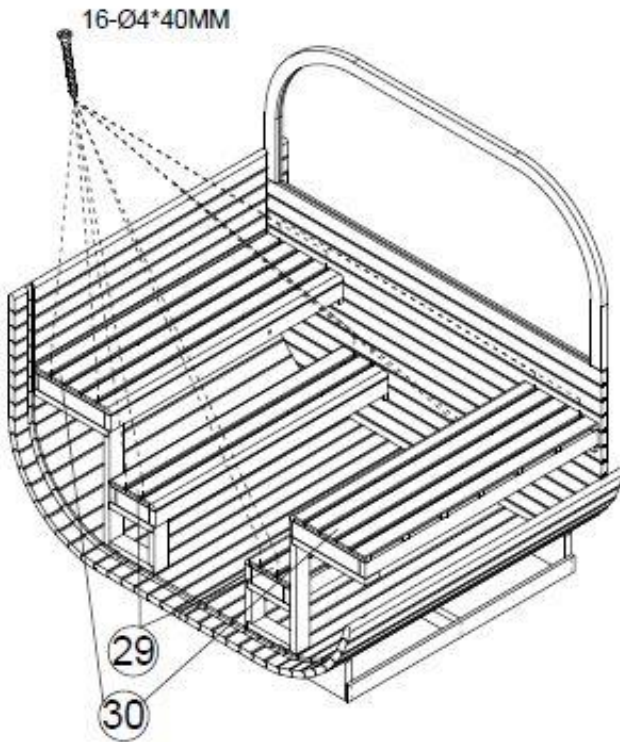

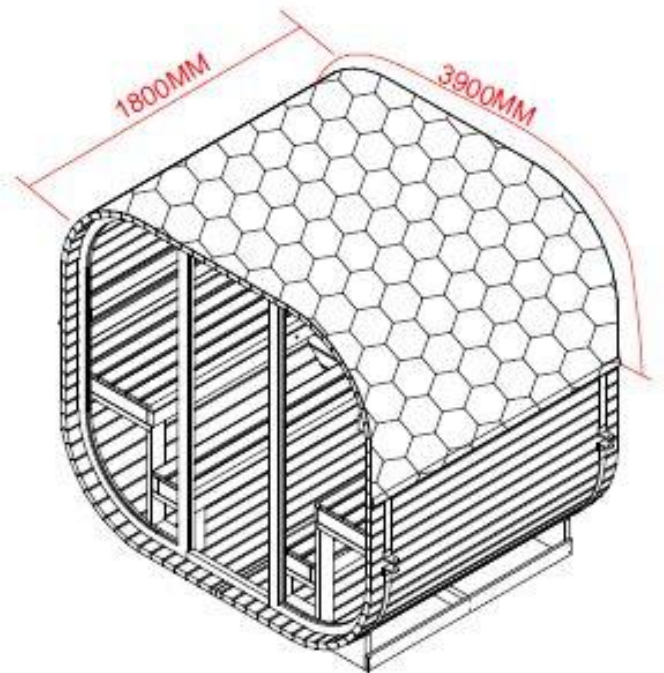
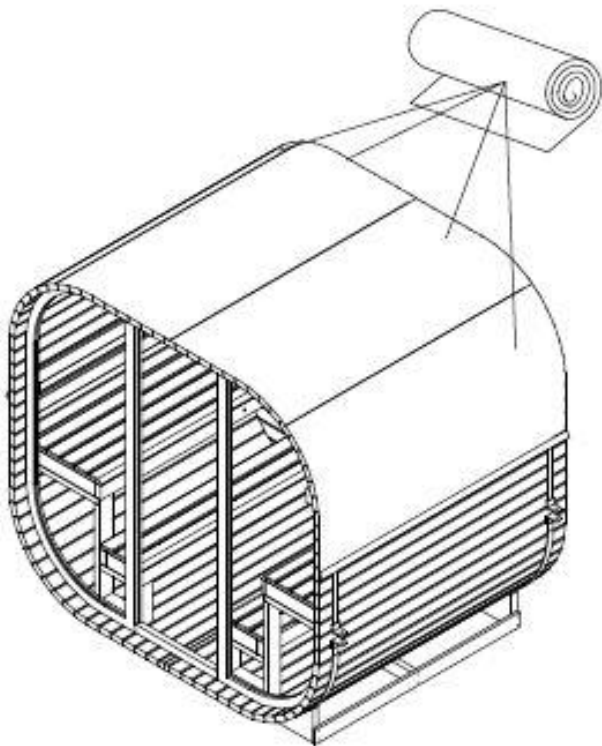
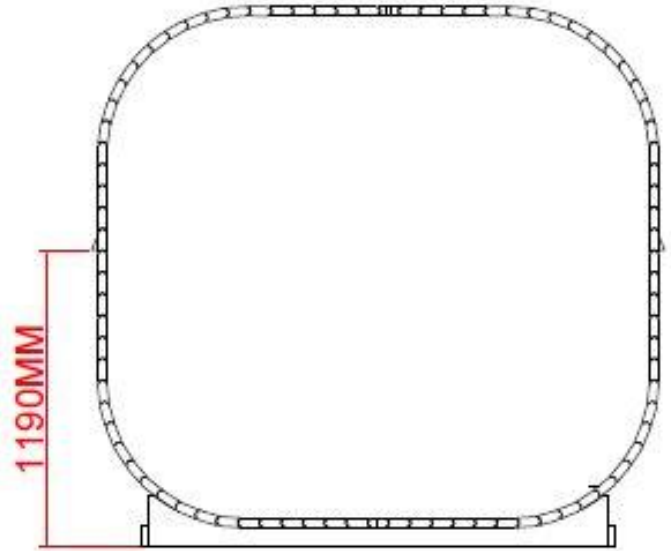
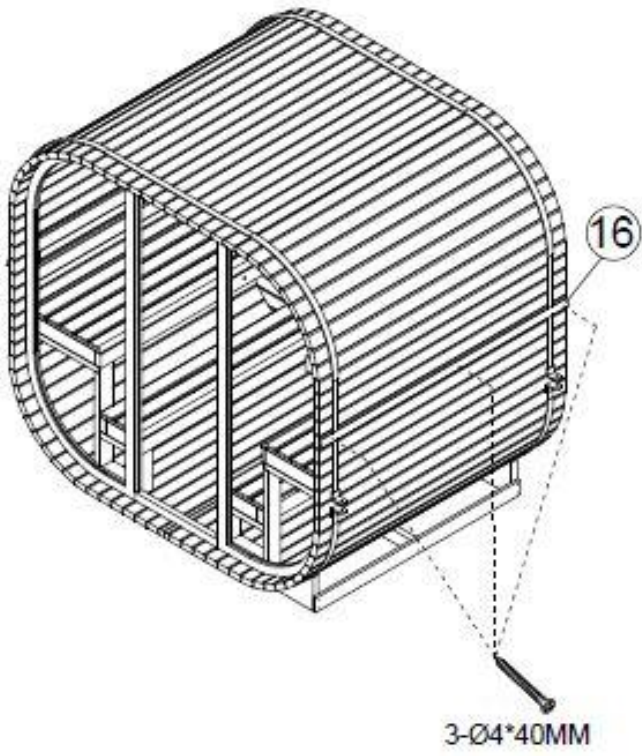

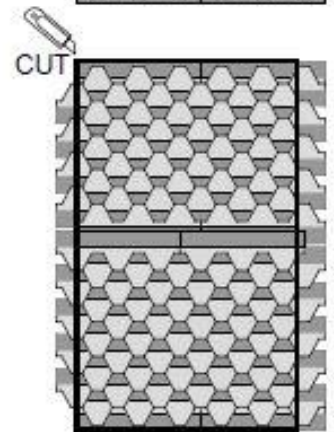
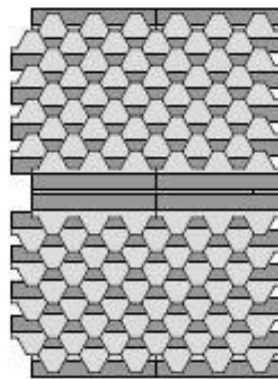
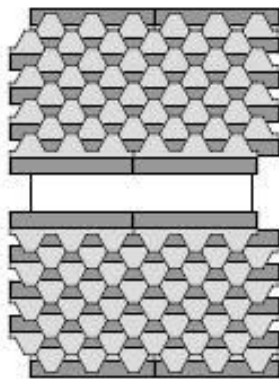
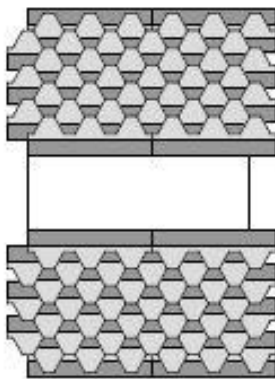
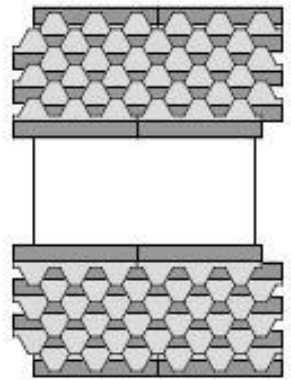
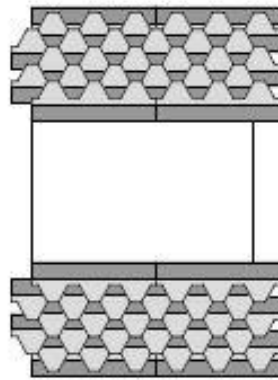
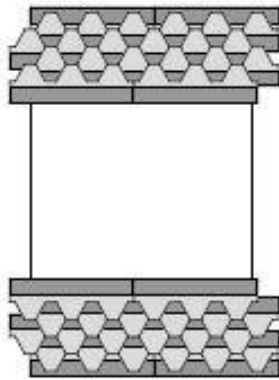
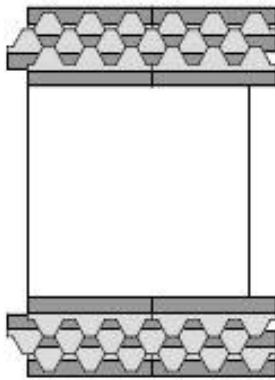
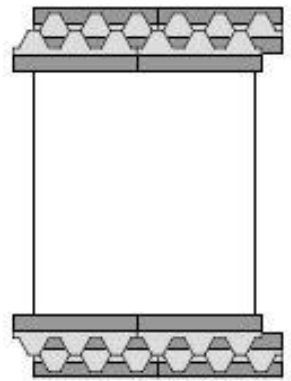
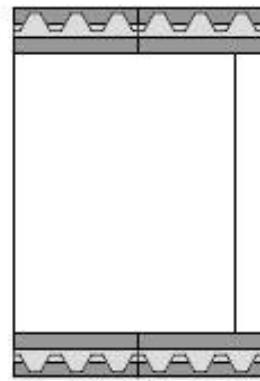
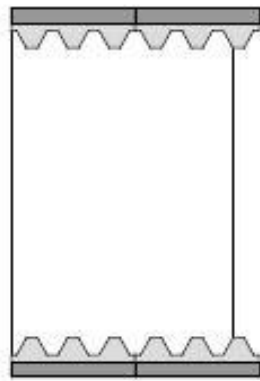
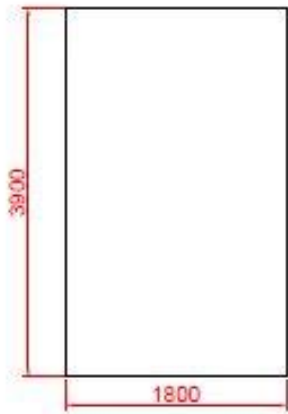

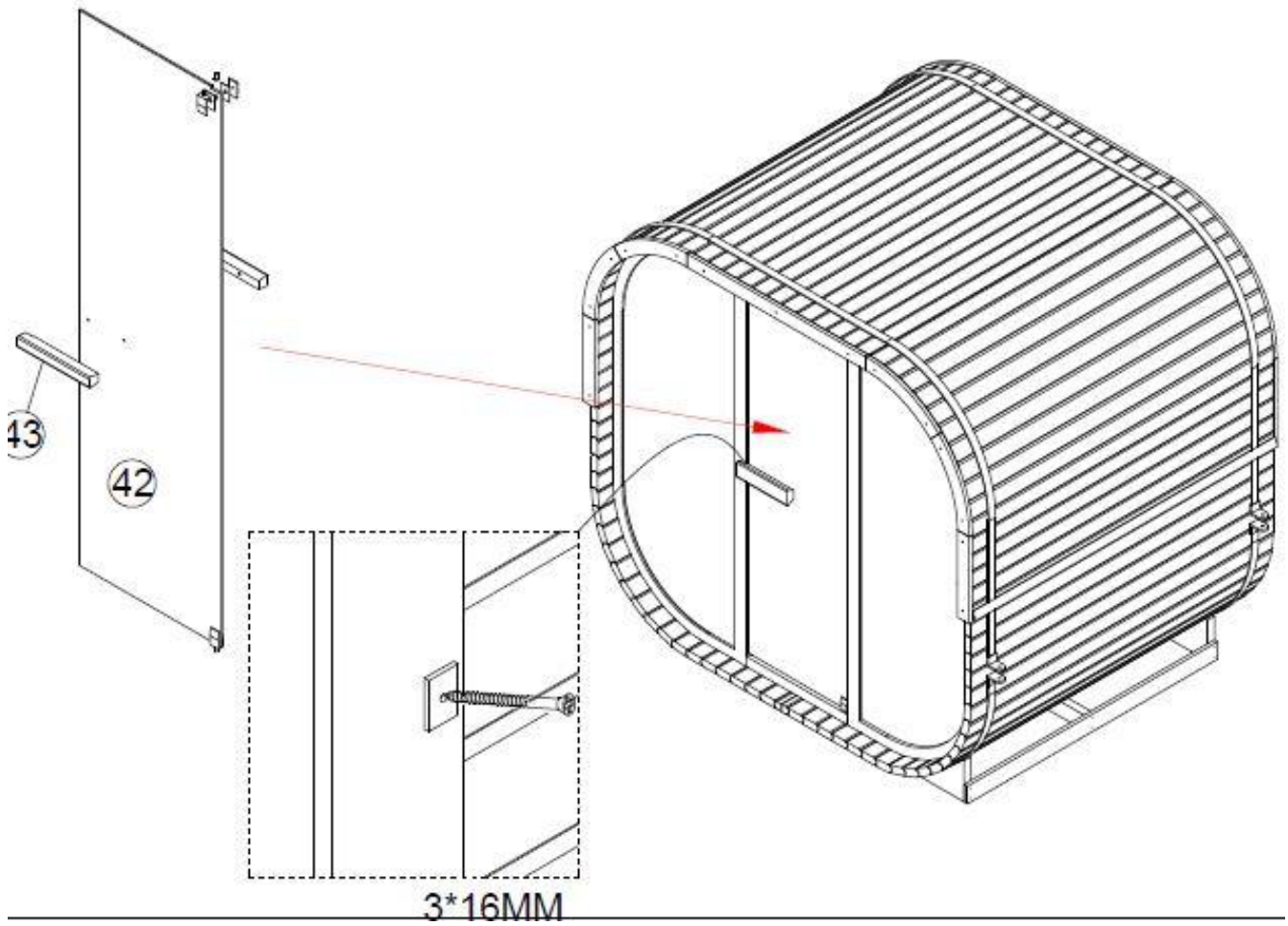
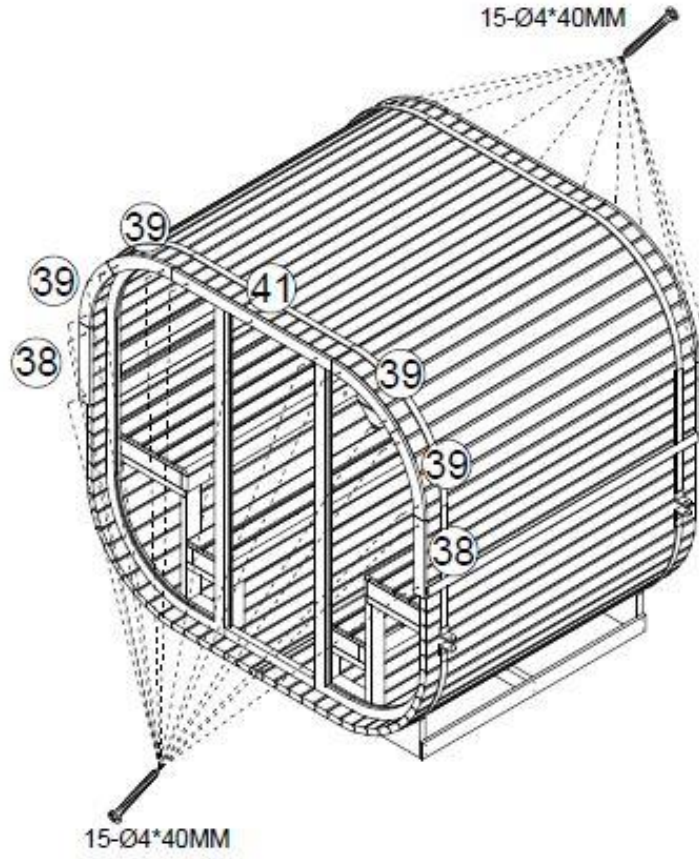

Maintenance instructions

Protection of wood

The outside of the sauna wall must be varnished after assembly.

This process protects the wood from the weather and extends the usability and durability of the wood and makes it resistant to water and insects!

The protective agent must be renewed according to the recommendations of the product used

Service:

1. switch off your sauna
2. use a vacuum cleaner to remove the dust from the cracks in the wood paneling
3. clean the cabin with a damp cotton cloth and use a small amount of soap if necessary. Rinse with a damp cloth.
- 4 Clean the glass with a window/glass cleaner and a soft cloth.
5. maintain the outside of the sauna every 2 years with a suitable product.

IMPORTANT!

The wood should only be treated with a protective product on the outside of the sauna.

No treatment may be carried out inside the sauna.

Do not use benzene, alcohol, chemical agents or strong cleaning agents for the sauna, as chemical products can damage the wood. Do not spray your sauna with water.

Please read the instructions supplied with the heater for the installation and use of the heater.

The heater may only be connected to the power supply by an authorized electrician in accordance with the applicable regulations..

Notes:
